

Echelle 1 : 4	<b>AFRICA RICE</b>	NOM:
	FOYER	Date:04/03/2019
A4 V		Feuille 2/10

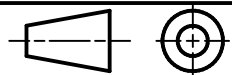

C ( 1 : 2 )

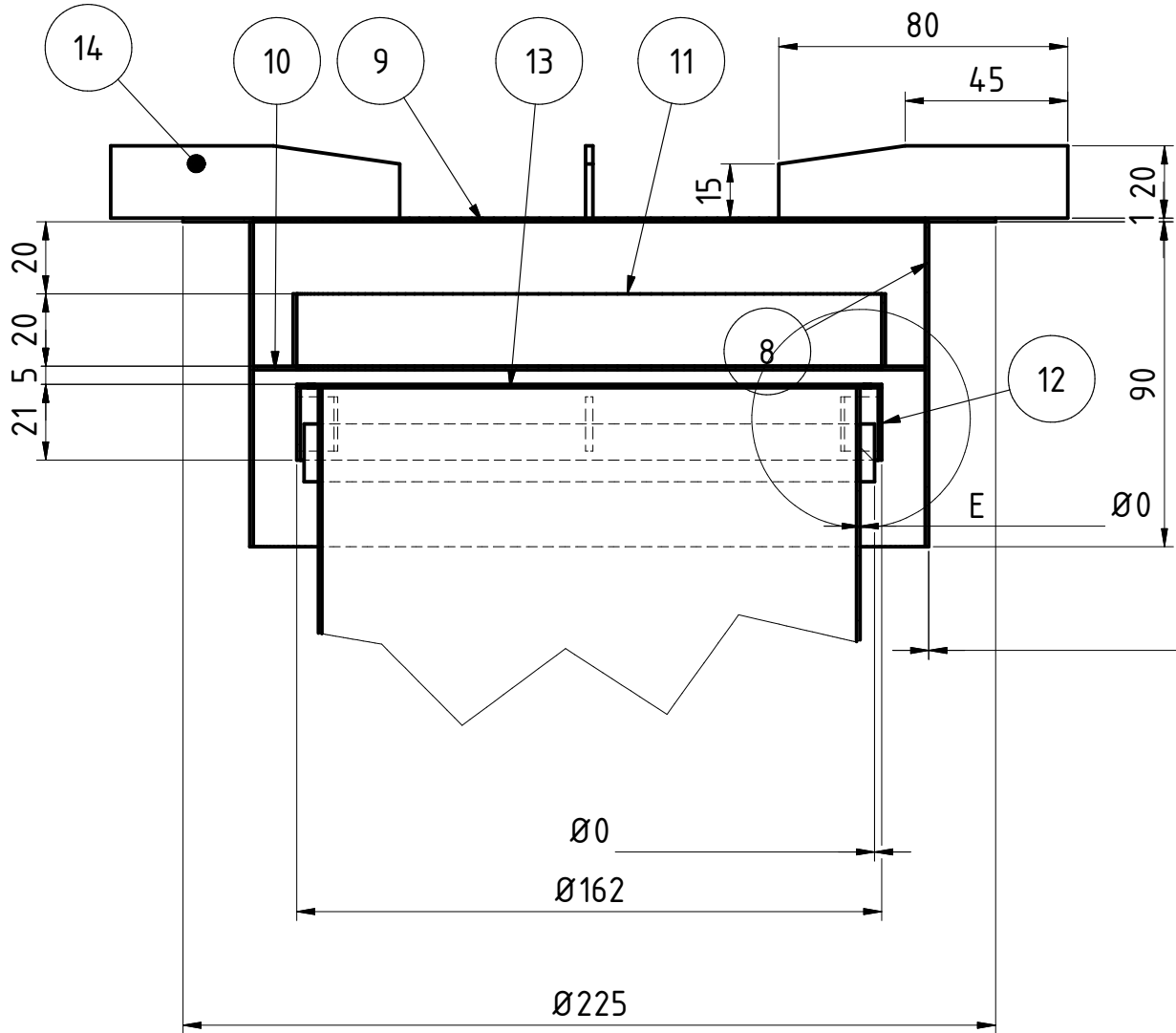

E ( 1 : 1 )

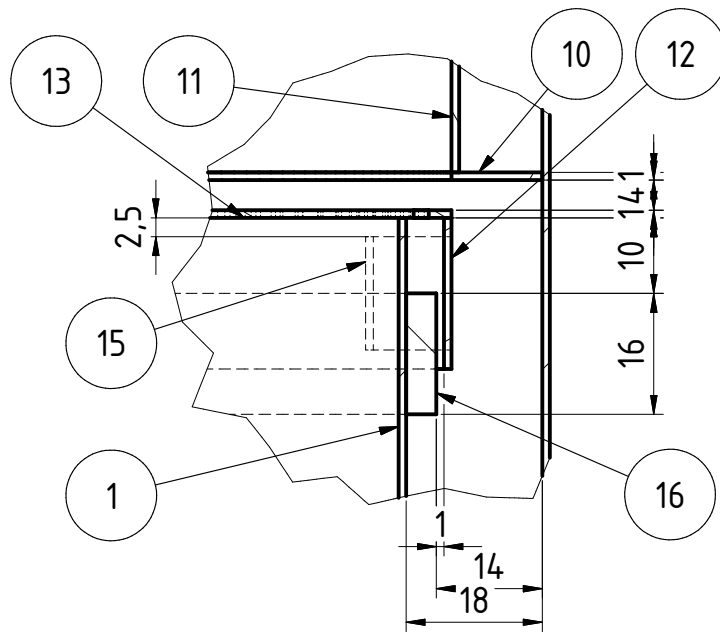

Echelle 1 : 2

**AFRICA RICE**

NOM:

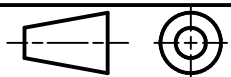

A4 V

FOYER

Date:04/03/2019

Feuille 3/10



J ( 1 : 2 )

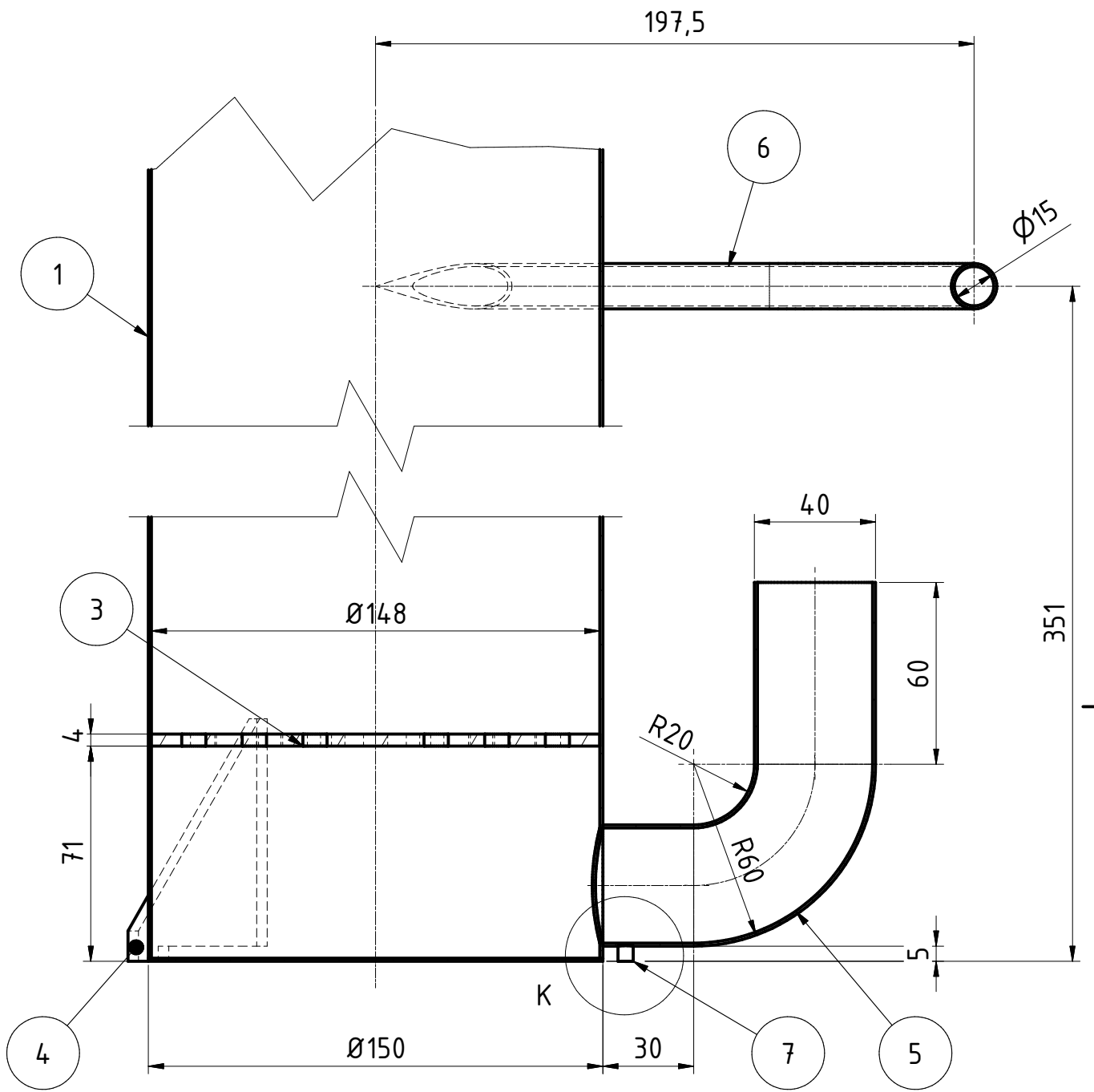

K ( 1 : 1 )

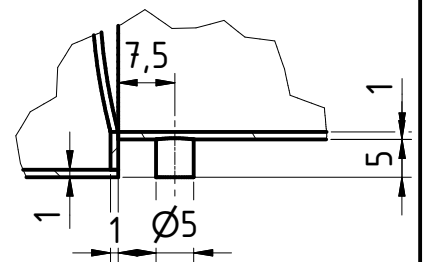

Echelle 1 : 4

**AFRICA RICE**

NOM:

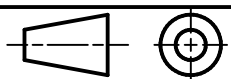

Date:04/03/2019

A4 V

FOYER

Feuille 4/10



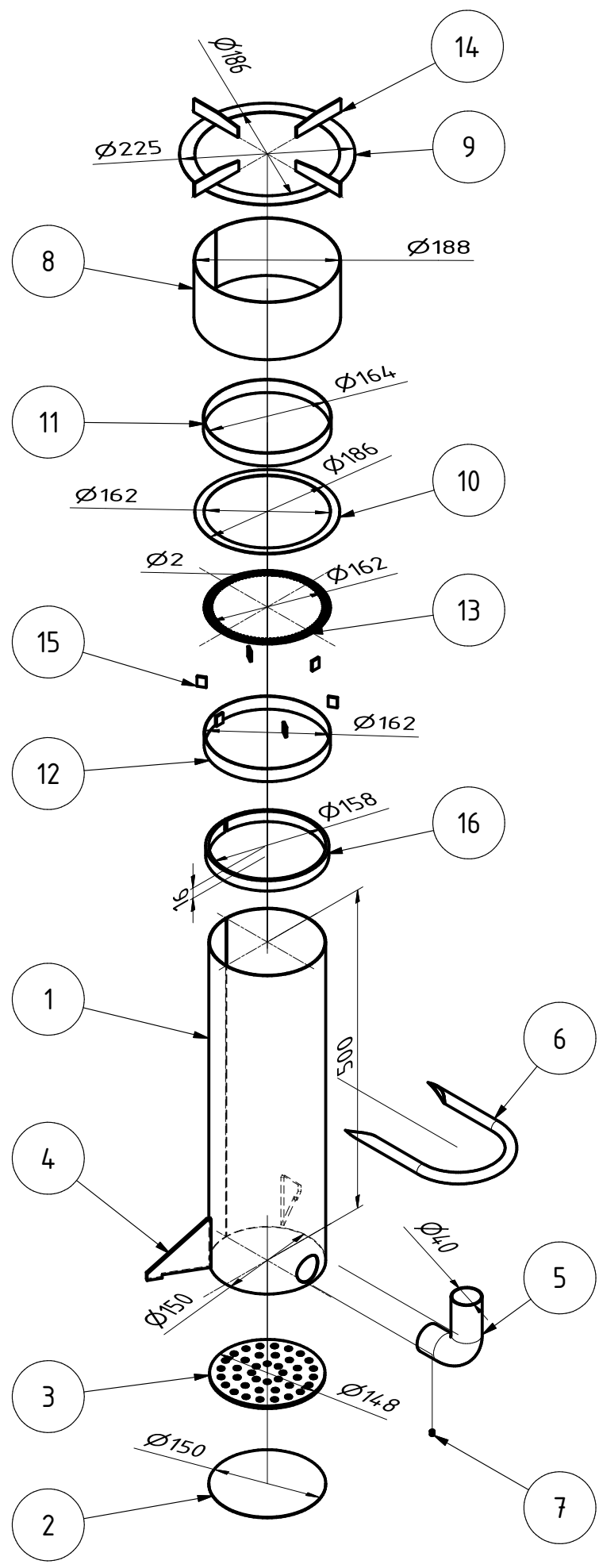

16	1		Acier	Tôle ép. 4
15	6		Acier	Tôle ép. 2
14	4	SUPPORT	Acier	Tôle ép. 2
13	1		Acier	Tôle ép. 1
12	1		Acier	
11	1		Acier	Tôle ép. 1
10	1		Acier	
9	1		Acier inoxydable	Tôle ép. 1
8	1	VIROLE SUP.	Acier inoxydable	Tôle ép. 1
7	1		Acier	
6	1	MANCHE	Acier inoxydable	Fer rond Ø15
5	1	CHEMINEE	Acier inoxydable	Tube rond Ø40
4	2	SUPPORT	Acier inoxydable	Tôle ép. 4
3	1		Générique	Tôle ép. 4
2	1	FOND	Acier	
1	1		Acier inoxydable	Tôle ép. 1
Rep.	Nbre.	DESIGNATION	MATIERE	OBSERVATIONS

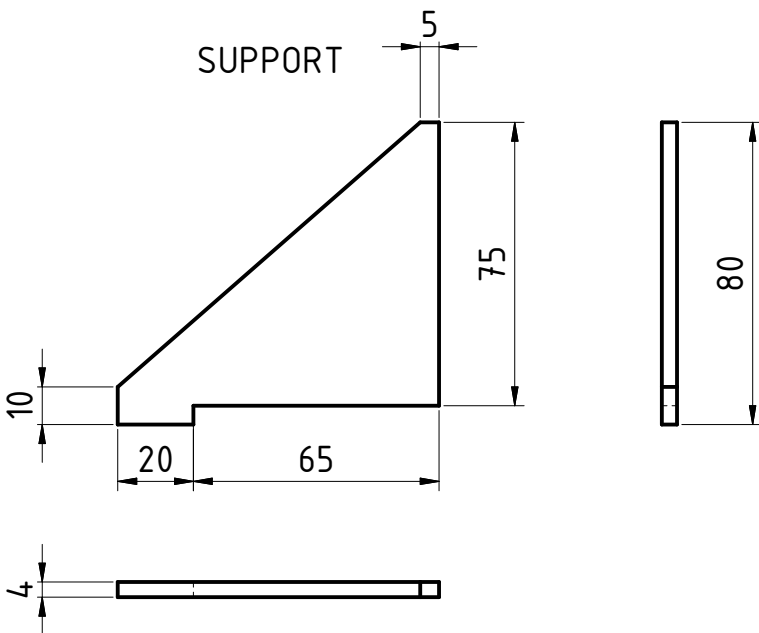
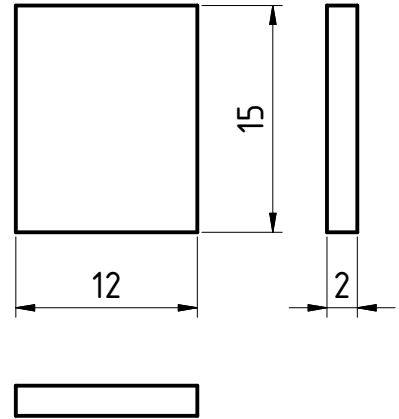
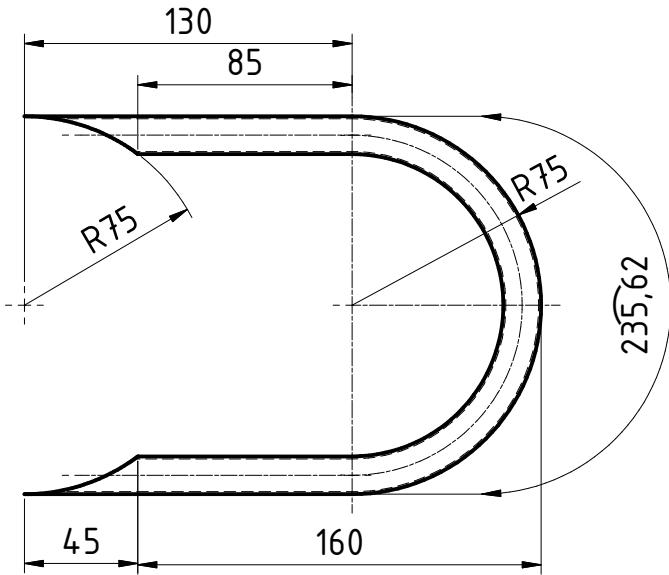
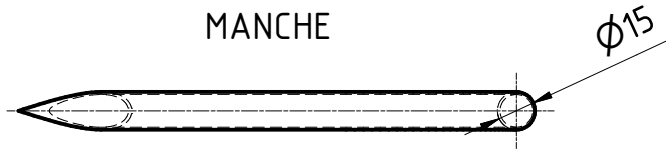

Echelle 1 : 3	<b>AFRICA RICE</b>	NOM:
	FOYER	Date:04/03/2019
A4 V		Feuille 7/10



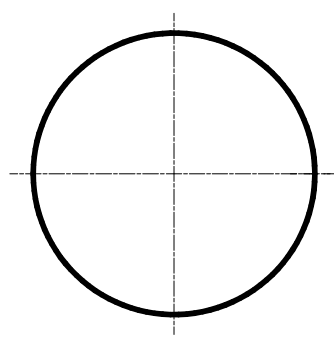
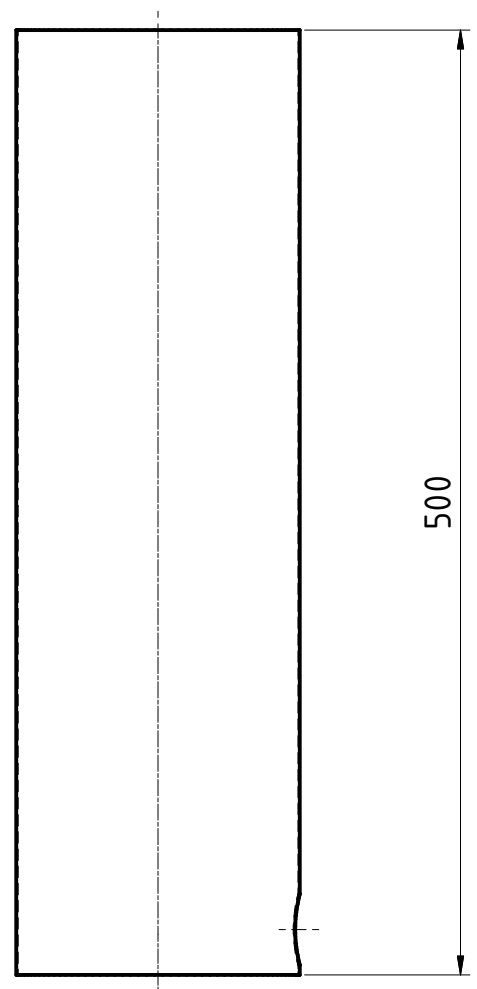
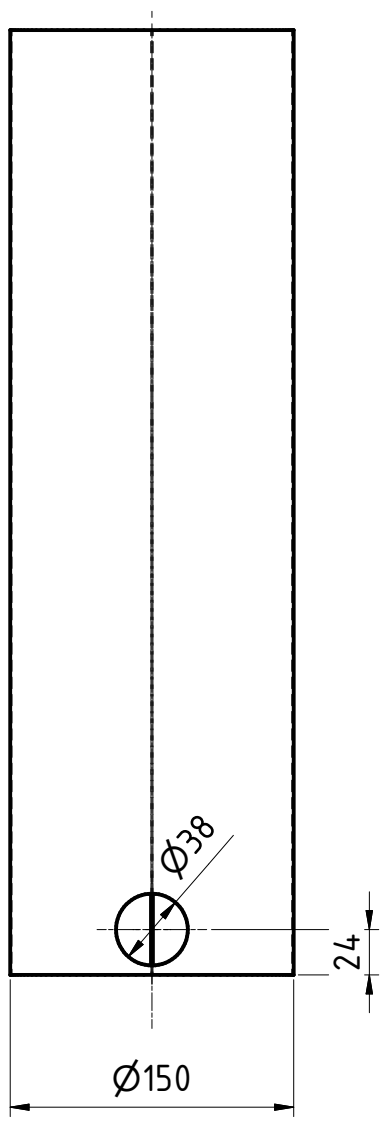

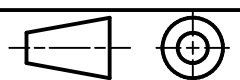

Echelle 1 : 4	<b>AFRICA RICE</b>	NOM:
	FOYER	Date:04/03/2019
A4 V		Feuille 8/10



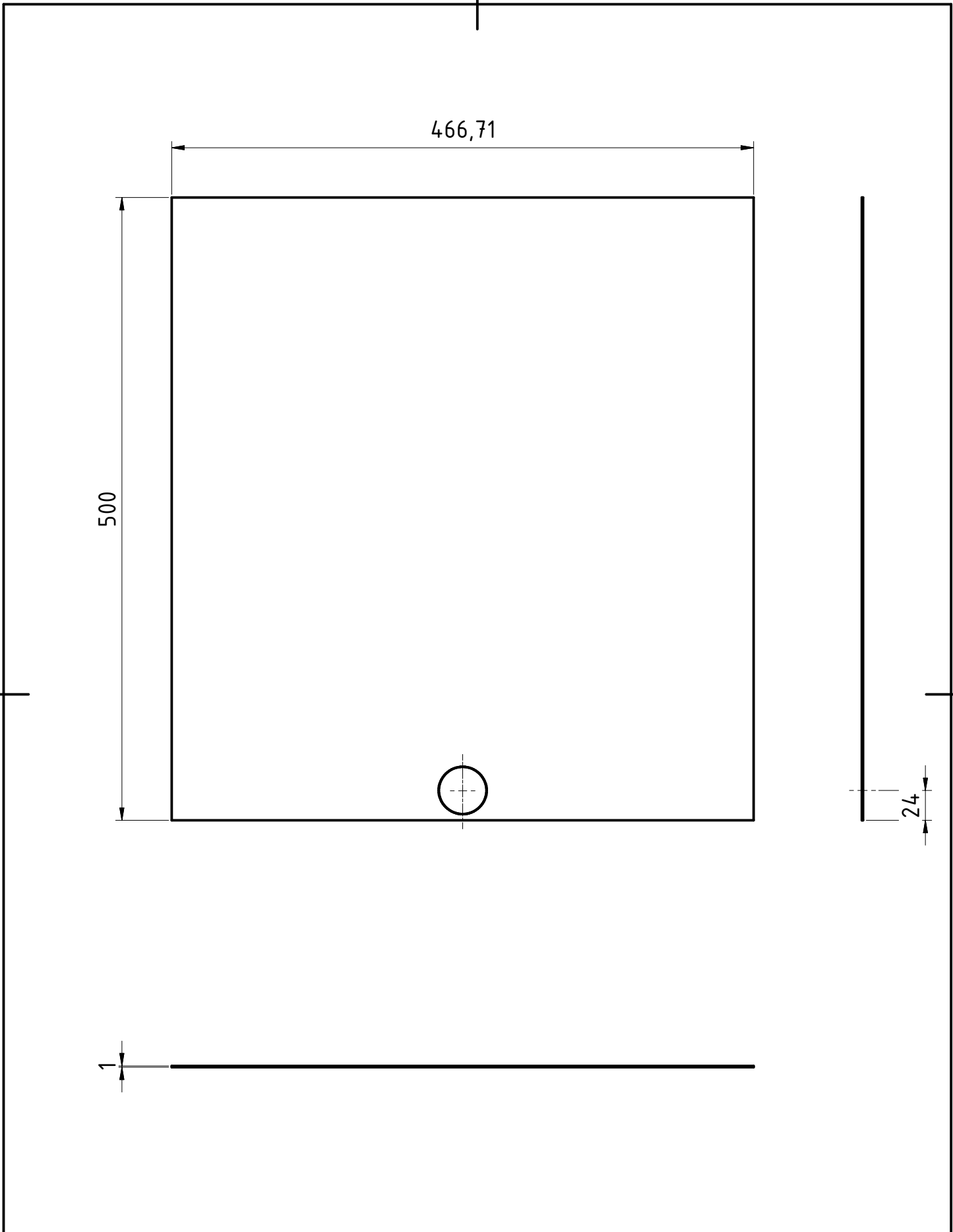

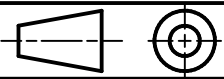

Echelle 1 : 4	<b>AFRICA RICE</b>	NOM:
	FOYER	Date:04/03/2019
A4 V		Feuille 9/10

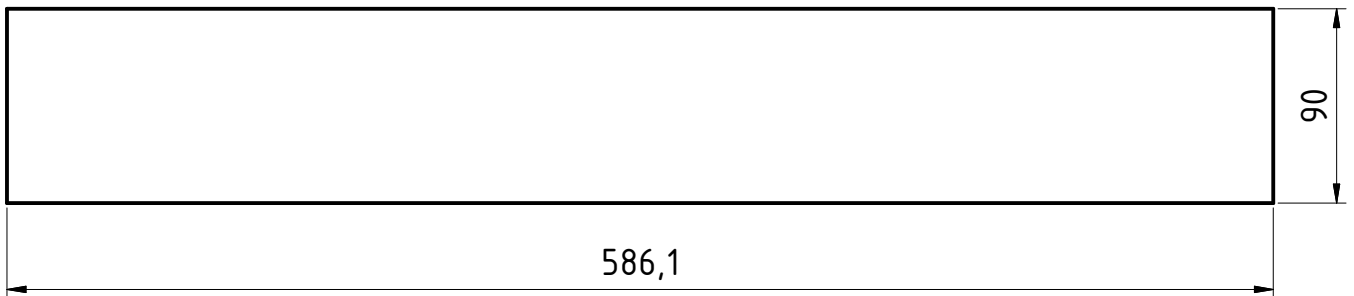
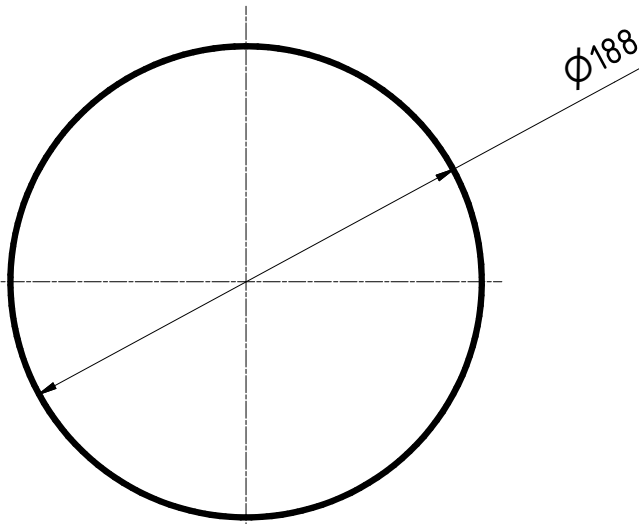
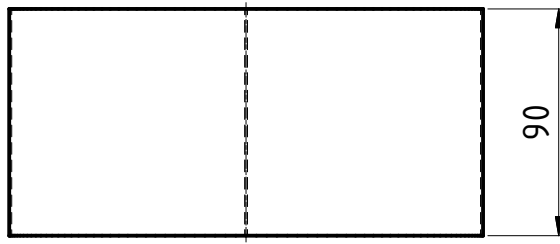

Echelle 1 : 3

**AFRICA RICE**

NOM:

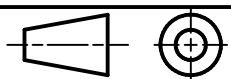

Date:04/03/2019

A4 V

FOYER

Feuille 10/10

